

SylSafe Twin TS C EM3 NM DA

Artikelnummer 0041770

SYLVANIA

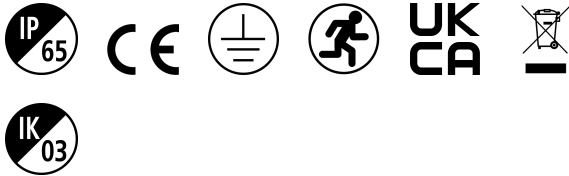

SylSafe Twin TS C EM3 NM DA is a dust and waterproof wall mounted twin LED projector for industrial applications. Two individually adjustable heads each delivering 200Lm. White housing colour. Non-maintained 3hr emergency operation with NiCd rechargeable battery. Recharge period 24 hours. Self testing with DALI monitoring capability. 400Lm, 3.23W, IK03, IP65, Power Factor 0.6. Class I electrical construction.

Technische Werte

Größe (mm)

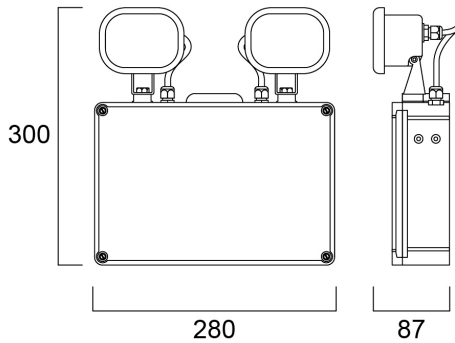

Photometrie

Distance [m]	Cone diameter [m]	Beam diameter [m]	Illuminance [lx]
0.5	1.23	0.77	344
1.0	2.46	1.54	86
1.5	3.69	2.31	38
2.0	4.92	3.08	23
2.5	6.15	3.85	14
3.0	7.38	4.62	10

Distance [m] Cone diameter [m] Illuminance [lx]
 — C0 - C180 (Half beam angle: 101.8°)

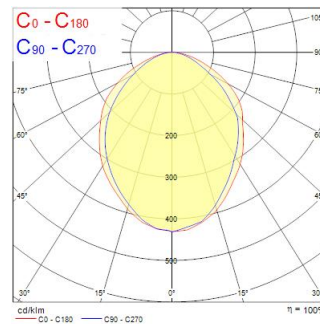

SylSafe Twin TS C EM3 NM DA

Artikelnummer 0041770

SYLVANIA

Allgemeine Daten

Produktname	SylSafe Twin TS C EM3 NM DA
Technologie	LED
Montage	Ceiling surface mounting
Allgemeine Anwendungsbereiche	Logistics & Industry
ETIM Klasse	EC001957
Garantie	5 Jahre

Optische Daten

Leuchtenlichtstrom (lm)	400
Systemeffizienz (lm/W)	124
Farbtemperatur (K)	5700
Farbwiedergabeindex (Ra)	70
Photobiological Risk Group	RG0
Luminous flux (emergency) (lm)	334

Elektrische Daten

Dauer Notbeleuchtung (h)	3
Primary Supply/Product voltage - min (V)	220
Primary Supply/Product voltage - max (V)	240
Leistungsfaktor der Lampe	0.6
Elektrische Schutzklasse	Class I
Vorschaltgerät benötigt	Yes
Stromstärke (mA)	25
Nennfrequenz (Hz)	50/60Hz

Physikalische Daten

Gehäusefarbe	White
IP Schutzart	IP65
IK Schutzart	IK03
Länge (mm)	280
Breite (mm)	87
Nominale Produkthöhe (mm)	300
Gewicht (kg)	1.7

Packaging

EAN Code	5410288417707
Einzelverpackung Länge (cm)	30.3
Einzelverpackung Breite (cm)	28.2
Einzelverpackung Tiefe (cm)	9.2
DUN14 (innen)	05410288417707
Anzahl an Einheiten je Außenverpackung	5
Außenverpackung Länge (cm)	49.5
Außenverpackung Breite (cm)	30.0
Außenverpackung Tiefe (cm)	32.5