

SylSafe Twin TS C EM3 NM DA

Item No: 0041770

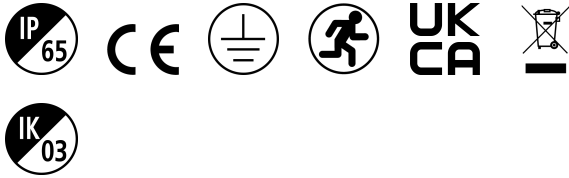

SylSafe Twin TS C EM3 NM DA is a dust and waterproof wall mounted twin LED projector for industrial applications. Two individually adjustable heads each delivering 200Lm. White housing colour. Non-maintained 3hr emergency operation with NiCd rechargeable battery. Recharge period 24 hours. Self testing with DALI monitoring capability. 400Lm, 3.23W, IK03, IP65, Power Factor 0.6. Class I electrical construction.

Technical Assets

Dimensions (mm)

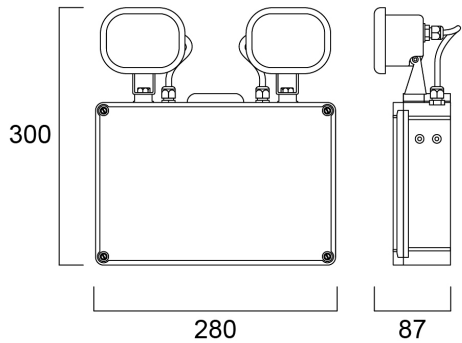

Photometrics

Distance [m]	Cone diameter [m]	Beam diameter [m]	Beam angle [°]	Illuminance [lx]
0.5	1.23	0.17	90°	344
1.0	2.46	0.34	90°	86
1.5	3.69	0.51	90°	38
2.0	4.92	0.68	90°	23
2.5	6.15	0.85	90°	14
3.0	7.38	1.02	90°	10

Distance [m] Cone diameter [m] Illuminance [lx]
 — C0 - C180 (Half beam angle: 101.8°)

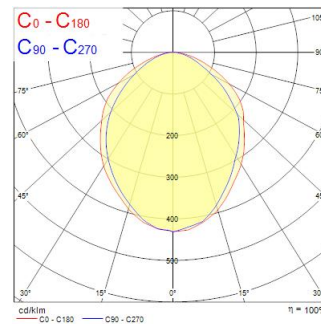

SylSafe Twin TS C EM3 NM DA

Item No: 0041770

SYLVANIA

General data

Product name	SylSafe Twin TS C EM3 NM DA
Technology	LED
Mount	Ceiling surface mounting
General application	Logistics & Industry
ETIM Class	EC001957
Warranty	5 years

Optical data

Fixture luminous flux (lm)	400
Luminaire efficacy (lm/W)	124
Correlated colour temperature (k)	5700
CRI (Ra)	70
Photobiological Risk Group	RG0
Luminous flux (emergency) (lm)	334

Electrical data

Emergency duration (h)	3
Primary Supply/Product voltage - min (V)	220
Primary Supply/Product voltage - max (V)	240
Lamp power factor	0.6
Electrical protection	Class I
Control gear required	Yes
Drive current (mA)	25
Nominal Frequency (Hz)	50/60Hz

Physical data

Housing colour	White
IP rating	IP65
IK rating	IK03
Nominal Product Length (mm)	280
Nominal Product Width (mm)	87
Nominal Product Height (mm)	300
Weight (kg)	1.7

Packaging

Product EAN number	5410288417707
Packaging single length / height (cm)	30.3
Packaging single width (cm)	28.2
Packaging single depth (cm)	9.2
DUN14 (outer)	05410288417707
Units per outer package	5
Packaging outer length / height (cm)	49.5
Packaging outer width (cm)	30.0
Packaging outer depth (cm)	32.5