

# REFLED PLATINUM RETRO ES50 360LM DIM 830 36 SL

Code article 0031925

**SYLVANIA**



Ultra-efficient LED GU10 range with the same look and size as traditional GU10 lamp. Save up to 95% on energy bills compared to halogen GU10 lamps. Energy Class A and best-in-class lumen efficacy. Sustainable and eco-friendly solution. Recreates backlight effect like halogen dichroic GU10 lamps. Full glass design - means no colours clashing between lamps and fixture. Last three times longer than the standard LED retrofit lamps. Remarkable 50,000 hours average rated life – reducing the hassle of frequent replacements. COOLFIT functionality – ensures overheating and overtemperature protection. Ideal for everyday lighting in homes, hotels, restaurants and more. Dimmable.

## Atouts techniques

### Dimensions (mm)

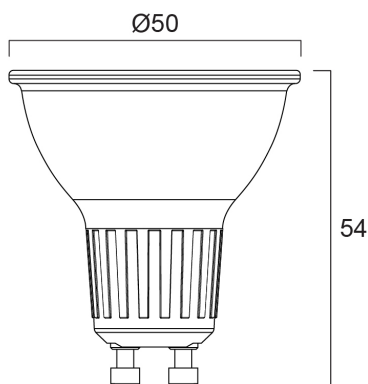

### Photométrie

# REFLED PLATINUM RETRO ES50 360LM DIM 830 36 SL

Code article 0031925

**SYLVANIA**

## Données générales

Nom du produit	REFLED PLATINUM RETRO ES50 360LM DIM 830 36 SL
Technologie	LED
Lamp shape	Reflector
Cap/Base	GU10
Lamp finish	Fresnel lens
Built in presence detector	NONE
Fixture rating	Open
General application	Residential & Consumer, Education, Hospitality, Museums & Galleries, Office, Residential & Consumer, Retail
Virtual assistant compatibility	N/A
ETIM Class	EC001959
Warranty	5 ans

## Données optiques

Useful luminous flux ( $\Phi_{use}$ )	360
Température de couleur (K)	3000
Couleur de lumière	Warm White
IRC (Ra)	80
Colour Variation Initial (SDCM)	SDCM6
Luminous Intensity (cd)	750
Beam Angle (°)	36
Photobiological Risk Group	RG1

## Caractéristiques électriques

Power consumption (W)	2
Wattage (W)	2
Equivalent watt (W)	50
Actuel (A)	0.016
Primary Supply/Product voltage - min (V)	220.0
Primary Supply/Product voltage - max (V)	240.0
Lamp power factor	0.5
Control gear required	No
Type d'appareillage	LED driver constant current
No. Of switching cycles before premature failures	>50000
Dimmable	Yes
Dimming method	N/A, Mains: leading / trailing edge
Courant d'appel (A)	3.36
Inrush Duration ( $\mu$ s)	800
Lamp Energy Label (class)	A
Nominal Frequency (Hz)	50/60Hz

## Durée de vie

Lifespan L70 B50	50000
------------------	-------

## Données physiques

Housing colour	Transparent
IP rating	IP20
Nominal Product Height (mm)	54
Nominal Product Diameter (mm)	50
Poids (kg)	0.046

# REFLED PLATINUM RETRO ES50 360LM DIM 830 36 SL

Code article 0031925

**SYLVANIA**

## Emballage

Product EAN number	5410288319254
Longueur simple de l'emballage (cm)	6.1
Largeur simple de l'emballage (cm)	5.1
Packaging single depth (cm)	8.2
DUN14 (inner)	15410288319251
Units per inner package	6
Packaging inner length / height (cm)	19.4
Packaging inner width (cm)	11.1
Packaging inner depth (cm)	9.2
DUN14 (outer)	25410288319258
Units per outer package	60
Packaging outer length / height (cm)	58.5
Packaging outer width (cm)	20.8
Packaging outer depth (cm)	20.8

## Sécurité

Consignes de nettoyage en cas de bris	Not applicable
Lampe à objectif spécial	No
Utilisation pour applications sèches uniquement	Yes
Ne convient pas à l'éclairage résidentiel	Yes
Safety message	Dimmable with approved dimmers