

# SylSafe Bay HB C EMC NM MS

Code article 0041734

**SYLVANIA**



SylSafe Bay HB C EMC NM MS is a dust and waterproof surface mounted emergency luminaire for industrial applications. Highbay optics for high ceiling applications. Non-maintained version for central battery systems. 177lm, 3W, IK03, IP65. Power Factor 0.44. Class II electrical construction.

## Atouts techniques

### Dimensions (mm)

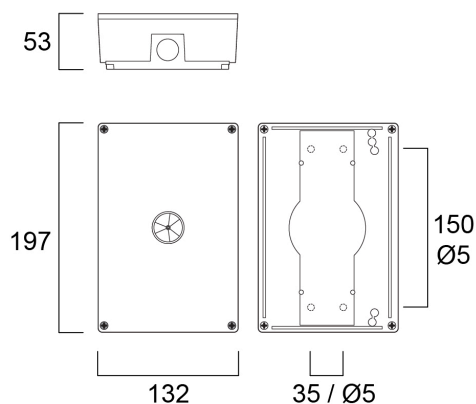

### Photométrie

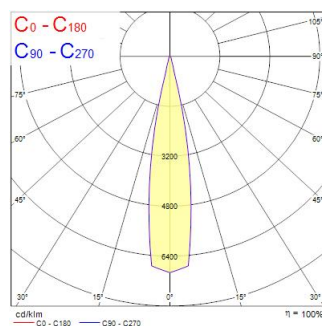
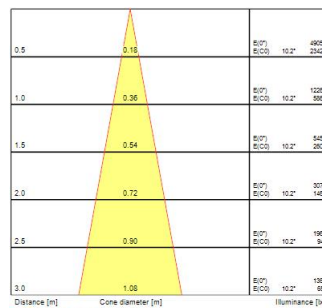

# SylSafe Bay HB C EMC NM MS

Code article 0041734

**SYLVANIA**

## Données générales

Nom du produit	SylSafe Bay HB C EMC NM MS
Technologie	LED
Montage	Ceiling surface mounting
General application	Education, Hospitality, Logistics & Industry, Museums & Galleries, Office, Retail
ETIM Class	EC001957
Warranty	5 ans

## Données optiques

Fixture luminous flux (lm)	177
Luminaire efficacy (lm/W)	59
Température de couleur (K)	5700
IRC (Ra)	75
Photobiological Risk Group	RG2
Luminous flux (emergency) (lm)	200

## Caractéristiques électriques

Emergency duration (h)	3
Primary Supply/Product voltage - min (V)	220
Primary Supply/Product voltage - max (V)	240
Lamp power factor	0.44
Electrical protection	Class II
Control gear required	Yes
Drive current (mA)	46
Nominal Frequency (Hz)	50/60Hz

## Données physiques

Housing colour	White
IP rating	IP65
IK rating	IK03
Longueur (mm)	197
Largeur (mm)	197
Nominal Product Height (mm)	53
Poids (kg)	0.588

## Emballage

Product EAN number	5410288417349
Longueur simple de l'emballage (cm)	23.0
Largeur simple de l'emballage (cm)	15.0
Packaging single depth (cm)	7.0
DUN14 (inner)	05410288417349
Units per outer package	5
Packaging outer length / height (cm)	42.2
Packaging outer width (cm)	25.2
Packaging outer depth (cm)	13.2