

Inset Trend 75 SW SQ IP44 WH NO-LMP

Code article 0084104

SYLVANIA

PROTM

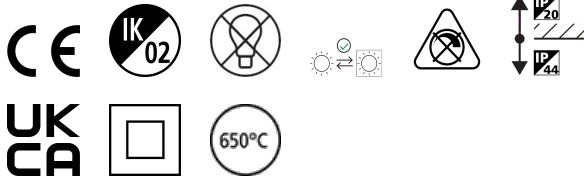

INSET TREND 75 SW SQ IP44 WH NO-LMP is the recessed housing frame to use with RefLED GU10 spotlight lamp Ø50mm - GU10 spotlight not included. Aluminium body, round bezel ring in white finish, IP44 degree of protection, class II, Suitable for internal environment only.

Atouts techniques

Dimensions (mm)

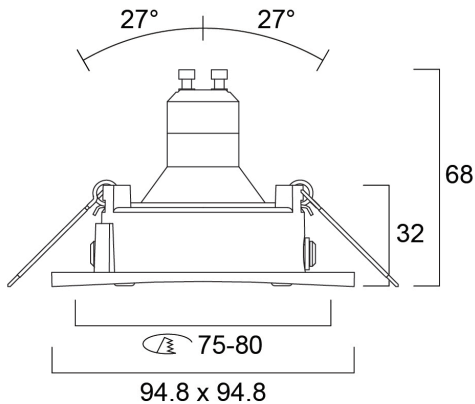

Photométrie

Inset Trend 75 SW SQ IP44 WH NO-LMP

Code article 0084104

SYLVANIA

Données générales

Nom du produit	Inset Trend 75 SW SQ IP44 WH NO-LMP
Technologie	Light Source Not Integrated
Cap/Base	GU10
Housing	Aluminium
Montage	Ceiling recessed mounting
Built in presence detector	NONE
Environment	Indoor
General application	Hospitality, Residential & Consumer
Operating temperature range (°C)	-10°C...+40°C
Virtual assistant compatibility	N/A
ETIM Class	EC001744
Numéro virtuel FI	4279667
Warranty	5 ans

Données optiques

Fixture luminous flux (lm)	1
Couleur de lumière	N/A
Colour Variation Initial (SDCM)	N/A
Distribution type	Symmetric
Photobiological Risk Group	Not applicable

Caractéristiques électriques

Lampe incluse	Fixture without Lightsource
Emergency type	
Consommation électrique totale (W)	0.1
Actuel (A)	0.001
Primary Supply/Product voltage - min (V)	220.0
Primary Supply/Product voltage - max (V)	240.0
THD (at 230 V, 50 Hz, full load, at 100% dimming level) \leq xx.x %	1
Electrical protection	Class II
Control gear required	No
Type d'appareillage	Not required
Dimmable	No
Dimming method	N/A
Nominal Frequency (Hz)	50/60Hz
Max. products per 10A C Breaker	20
Max. products per 16A C Breaker	30
Connectable conductor cross section - Max (mm ²)	1.5

Données physiques

Housing colour	White
IP rating	IP44/20
IK rating	IK02
Diffuser finish	Other
Diffuser material	None
Finition réflecteur	Not Applicable
Longueur (mm)	95
Largeur (mm)	95
Nominal Product Height (mm)	100
Built-in diameter (mm)	75
Poids (kg)	0.18
Recessed Depth (mm)	115

Inset Trend 75 SW SQ IP44 WH NO-LMP

Code article 0084104

SYLVANIA

Emballage

Product EAN number	5410288841045
Longueur simple de l'emballage (cm)	13.0
Largeur simple de l'emballage (cm)	10.0
Packaging single depth (cm)	9.0
DUN14 (inner)	15410288841042
Units per outer package	30
Packaging outer length / height (cm)	52.5
Packaging outer width (cm)	27.5
Packaging outer depth (cm)	28.0

Sécurité

Glow Wire Test (°C)	650
Condition de fonctionnement optimal (° C)	-10-40