

Inverto Dir/Ind WW Eb Silver

Code article 3080099

SYLVANIA

PROTM



Surface Wall mounted direct / indirect luminaire, wire to base with pluggable connection for easy installation, suitable for looping, silver coloured aluminium housing, 3130lm (2 x 1565lm), 30W, 104lm/W,3000K, 350mA, CRI:80, 40° beam Angle, non-dimmable, IP65, IK07, lifespan: 60,000hrs (L80:B20), 23.00x32.2x11.5mm.

Atouts techniques

Dimensions (mm)

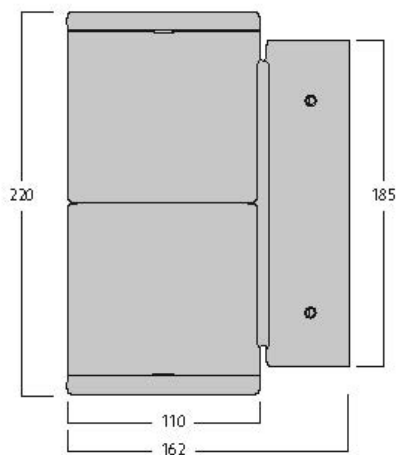

Photométrie

Distance [m]	Cone diameter [m]	E ₀ ' [lx]	E ₀ C ₀ ' [lx]	E ₀ C ₉₀ ' [lx]
0.5	0.36	1259	193'	804
1.0	0.72	314'	193'	125
1.5	1.08	139	193'	55
2.0	1.44	78'	193'	33
2.5	1.80	50	193'	21
3.0	2.16	30	193'	14

Distance [m] Cone diameter [m] Illuminance [lx]
 C0 - C180 (Half beam angle: 39.6°)

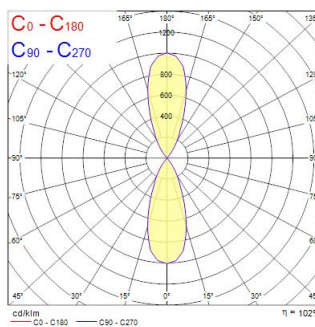

Inverto Dir/Ind WW Eb Silver

Code article 3080099

SYLVANIA

Données générales

Nom du produit	Inverto Dir/Ind WW Eb Silver
Technologie	LED
Cap/Base	N/A
Housing	Aluminium
Montage	Wall surface mounted
Environment	Internal/External
General application	Hospitality
Operating temperature range (°C)	-25°C...+25°C
Performance ambient temperature Tq (°C)	25
ETIM Class	EC002892
Numéro virtuel SE	7702959
Warranty	5 ans

Données optiques

Fixture luminous flux (lm)	3130
Luminaire efficacy (lm/W)	104
LOR (%)	100
Température de couleur (K)	3000
Couleur de lumière	Warm White
IRC (Ra)	80
Colour Consistency (SDCM)	3
Chromaticité réglable	N
Beam Angle (°)	40
Photobiological Risk Group	RG1

Caractéristiques électriques

Consommation électrique totale (W)	30
Primary Supply/Product voltage - min (V)	220
Primary Supply/Product voltage - max (V)	240
Electrical protection	Class II
Type d'appareillage	Electronic ballast
Dimmable	No
Dimming method	N/A
Drive current (mA)	350
Courant d'appel (A)	45
Inrush Duration (µs)	20
Energy Efficiency Class (A->G) of contained light source	D
Nominal Frequency (Hz)	50/60Hz
Max. products per 10A C Breaker	50
Max. products per 16A C Breaker	80

Durée de vie

Lifespan L70 B50	60000
Lifespan L80 B20	60000
Lifespan L90 B10	56100

Données physiques

Housing colour	RAL 9022 - Pearl light grey
IP rating	IP65
IK rating	IK07
Diffuser finish	Transparent
Diffuser material	Glass
Longueur (mm)	162
Largeur (mm)	110
Nominal Product Height (mm)	220
Poids (kg)	2.444

Inverto Dir/Ind WW Eb Silver

Code article 3080099

SYLVANIA

Emballage

Product EAN number	8711971800996
Longueur simple de l'emballage (cm)	23.0
Largeur simple de l'emballage (cm)	32.3
Packaging single depth (cm)	11.5
DUN14 (inner)	08711971800996
Units per outer package	1
Packaging outer length / height (cm)	23.0
Packaging outer width (cm)	32.3
Packaging outer depth (cm)	11.5

Sécurité

Condition de fonctionnement optimal (° C)	-25-25
---	--------