

# REFLED PLATINUM RETRO ES50 360LM 830 36 SL

Item No: 0031921

**SYLVANIA**



Ultra-efficient LED GU10 range with the same look and size as traditional GU10 lamp. Save up to 95% on energy bills compared to halogen GU10 lamps. Energy Class A and best-in-class lumen efficacy. Sustainable and eco-friendly solution. Recreates backlight effect like halogen dichroic GU10 lamps. Full glass design - means no colours clashing between lamps and fixture. Last three times longer than the standard LED retrofit lamps. Remarkable 50,000 hours average rated life – reducing the hassle of frequent replacements. COOLFIT functionality – ensures overheating and overtemperature protection. Ideal for everyday lighting in homes, hotels, restaurants and more. Non-Dimmable.

## Technical Assets

### Dimensions (mm)

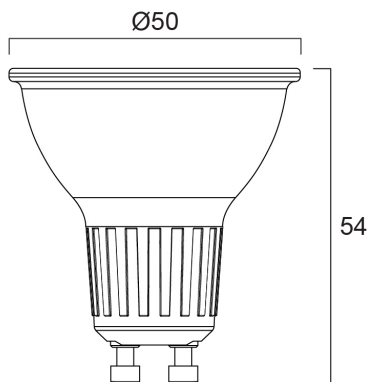

### Photometrics

# REFLED PLATINUM RETRO ES50 360LM 830 36 SL

Item No: 0031921

**SYLVANIA**

## General data

Nome do produto	REFLED PLATINUM RETRO ES50 360LM 830 36 SL
Tecnologia	LED
Forma da lâmpada	Reflector
Casquilho	GU10
Acabamento da lâmpada	Fresnel lens
Detetor de presença incorporado	NONE
Luminária	Open
Aplicação geral	Residencial & Consumer, Educação, Hotelaria, Museums & Galleries, Escritórios, Residencial & Consumer, Retalho
Compatibilidade com assistente virtual	N/A
ETIM	EC001959
Garantia	5 anos

## Optical data

Useful luminous flux ( $\Phi_{use}$ )	360
Temperatura de cor (K)	3000
Cor da luz	Warm White
CRI	80
Varição da cor (SDCM)	SDCM6
Luminous Intensity (cd)	750
Ângulo do feixe (°)	36
Grupo de risco fotobiológico	RG1

## Electrical data

Power consumption (W)	2
Potência	2
Equivalent watt (W)	50
Supply current (A)	0.028
Tensão de alimentação do produto – mín. (V)	220.0
Tensão de alimentação do produto – máx. (V)	240.0
Fator de potência	0.4
Control gear required	No
Sistema de controlo	LED driver constant current
No. Of switching cycles before premature failures	>50000
Regulável	No
Modo de regulação	N/A
Corrente de arranque (A)	15.4
Duração da corrente de arranque ( $\mu$ s)	2
Lamp Energy Label (class)	A
Frequência nominal (Hz)	50/60Hz

## Lifetime data

Vida útil L70 B50	50000
-------------------	-------

## Physical data

Cor do corpo	Transparent
Proteção IP	IP20
Altura nominal do produto (mm)	54
Nominal Product Diameter (mm)	50
Peso (kg)	0.046

# REFLED PLATINUM RETRO ES50 360LM 830 36 SL

Item No: 0031921

**SYLVANIA**

## Packaging

Código EAN	5410288319216
Comprimento / altura da embalagem individual (cm)	6.1
Largura da embalagem individual (cm)	5.1
Profundidade da embalagem individual (cm)	8.2
DUN14 (inner)	15410288319213
Units per inner package	6
Packaging inner length / height (cm)	19.4
Packaging inner width (cm)	11.1
Packaging inner depth (cm)	9.2
DUN14 (outer)	25410288319210
Unidades por embalagem exterior	60
Comprimento / altura da embalagem exterior (cm)	58.5
Largura da embalagem exterior (cm)	20.8
Profundidade da embalagem exterior (cm)	20.8

## Safety data

Breakage cleaning instructions	Not applicable
Special purpose lamp	No
Dry applications use only	Yes
Suitable for household illumination	Yes
Safety message	Not Suitable for totally enclosed fixtures