

OneTrack 3phase 3m Black 9000b-3/b-st

Item No: 9200307

SYLVANIA

PROTM

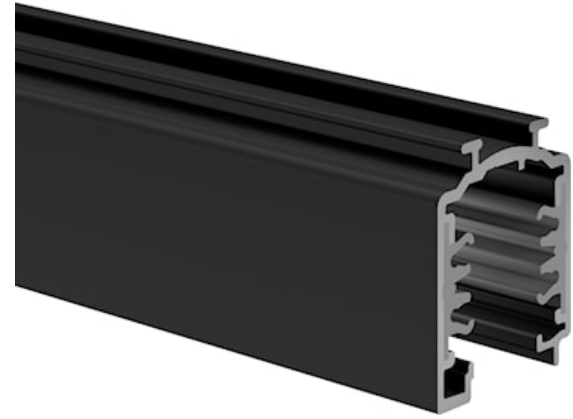

Onetrack 3-phase - 3 circuit track L1/L2/L3/Neutral/ground 16A/440V, circuits can be controlled individually, aluminium body, suitable for surface and suspended mounting, 3000 x 30.7 x 37.8 mm (L x W x H), black (RAL 9005).

Technical Assets

Dimensions (mm)

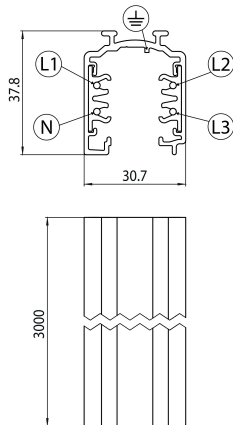

Photometrics

OneTrack 3phase 3m Black 9000b-3/b-st

Item No: 9200307

SYLVANIA

General data

Product name	OneTrack 3phase 3m Black 9000b-3/b-st
Technology	Non - Electrical Device
Accessory type	Electrical
Type of accessory	Track
Housing	Aluminium
Mount	Suspended, Ceiling surface mounting, Wall surface mounted
General application	Museums & Galleries, Office
ETIM Class	EC000101
Warranty	5 years

Electrical data

Primary Supply/Product voltage - min (V)	220
Primary Supply/Product voltage - max (V)	240
Electrical protection	Class I

Physical data

Housing colour	Black
Nominal Product Length (mm)	3000
Nominal Product Width (mm)	30.7
Nominal Product Height (mm)	37.8
Weight (kg)	2.25

Packaging

Product EAN number	4012289003074
Packaging single length / height (cm)	306.0
Packaging single width (cm)	3.3
Packaging single depth (cm)	3.5
Units per outer package	276
Packaging outer length / height (cm)	310.0
Packaging outer width (cm)	80.0
Packaging outer depth (cm)	50.0